

CARLYLE

5F & 5H Compressors technical datas

PHYSICAL DATA AND DIMENSIONS

DIMENSIONS

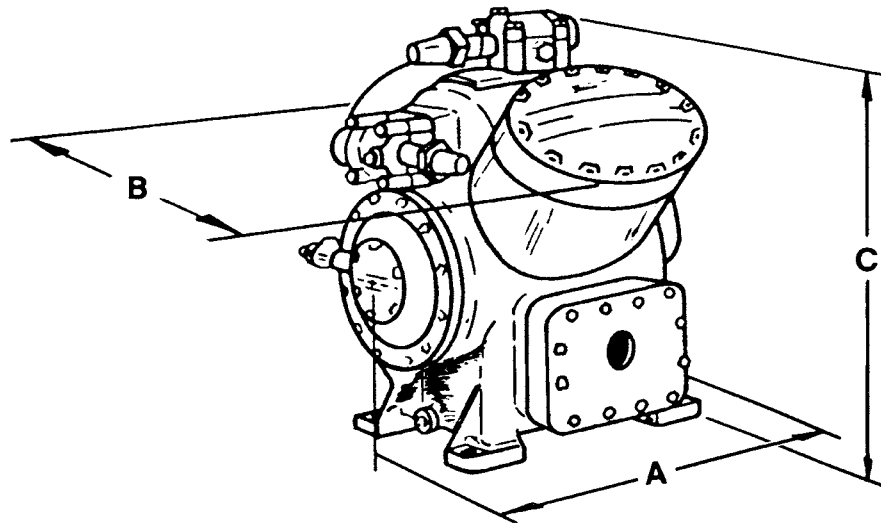

PHYSICAL DATA

COMPRESSOR	5F				5H				5H*			
	20	30	40	60	40	60	80	120	46	66	86	126
OPERATING WT	175	215	355	400	610	795	1115	1580	610	795	1115	1580
COMPRESSOR												
Nominal Hp	3-	5-	7.5-	10-	20-	30-	40-	60-	40-	60-	75-	125-
Displ cfm at 1750 rpm	19.9	29.8	39.8	59.6	92.4	138.4	184.7	276.8	115.5	173.0	231.0	346.0
Cylinders	2	3	4	6	4	6	8	12	4	6	8	12
Oil (pt)	5	5.5	12	13	18	21	41	81	18	21	41	81
Bore (in.)	2½				3¼				3¼			
Stroke (in.)	2				2¼				3/16			
Max rpm	1750											
Min rpm	400 (Required for proper lubrication)											
Min rpm, Cap. Control	600	700	800	900	800	900	1100	900	800	900	1100	900
High Side Max Pressure	400 psig											
Low Side Max Pressure	245 psig											
DIMENSIONS (in.)												
A	15¾	18	21½	23½	30½	31½	43¾	47	30½	31½	43¾	47
B	18¾	20¾	19	21	24½	27¼	24½	27¾	24½	27¼	24½	27¾
C	18¾	18	20¾	24½	29	29¾	32	34¾	29	29¾	32	34¾
CONNECTIONS (in.)												
Suction ODF	1½	1¾	1¾	2½	2¾	3¾	3¾	4¾	2¾	3¾	3¾	4¾
Discharge ODF	¾	1¾	1¾	1¾	2¾	2¾	3¾	3¾	2¾	2¾	3¾	3¾

\*Increased displacement compressors (5H46,66,86,126) not available for belt drive duty.

## 5F &amp; 5H OPEN COMPRESSORS / SIGNIFIANCE CHART

References	Service Valves	Pressure Switches	W.C Heads	Replacement	
				Newman	Reman
5H120-A194	YES	YES	NO	5H120-S219	5H120-A219
5H120-S219	YES	NO	NO	-	-
5H120-A219	YES	NO	NO	-	-
5H126-394	YES	YES	NO	5H126-S219	5H126-A219
5H126-S219	YES	NO	NO	-	-
5H126-A219	YES	NO	NO	-	-
5H120-C864	YES	NO	YES	-	-
5H126-C864	YES	NO	YES	-	-
5H120-C149	YES	NO	NO	-	-
5H126-C149	YES	NO	NO	-	-
5H120-C884	NO	NO	NO	-	-

References	W.C Heads	N° of Unloaders	Replacement	
			Newman	Reman
5F30-C644	NO	0	5F30-S644	5F30-A644
5F30-OLD C'CASE	NO	0	-	5F30-A189
5F30-C654	NO	1	5F30-S664	5F30-A664
5F30-C664	NO	2	5F30-S664	5F30-A664
5F30-C864	YES	2	-	-

## APPLICATION HIGH AND MEDIUM TEMPERATURE R404 / R507A

Capacity kW	Displacement m <sup>3</sup> /h	Cooling capacity Watts - Evaporating temp.				Model reference
		0°C	-5°C	-7°C	-15°C	
7.4	20.03	18810	15040	14100	11910	5F20
11	42.18	28270	22670	21260	17980	5F30
15	56.33	37740	30280	28410	24030	5F40
23	83.46	56650	45460	42670	36120	5F60
37	130.79	87480	70770	6662	56640	5H40
44	163.48	108052	87790	81640	70260	5H46
55	195.90	131280	106210	99980	85020	5H60
74	244.87	162870	131870	124170	105640	5H66
74	261.43	175090	141670	133380	113430	5H80
92	326.96	217160	175730	165450	14071	5H86
110	390.66	262620	212490	200040	170110	5H120
132	489.74	325750	263670	248280	211190	5H126

## APPLICATION LOW TEMPERATURE R404 / R507A

Capacity kW	Displacement m <sup>3</sup> /h	Cooling capacity Watts - Evaporating temp.				Model reference
		-20°C	-25°C	-28°C	-35°C	
5.5	20.03	7220	5470	4630	2700	5F20
7.4	42.18	10860	8180	6890	3990	5F30
11	56.33	14170	11010	9290	540	5F40
18	84.36	21930	16590	14010	8110	5F60
29	130.79	34800	26420	22350	13070	5H40
37	163.48	43170	32770	27720	16180	5H46
44	195.90	52290	39740	33640	19700	5H60
55	244.87	6510	49540	41980	24680	5H66
55	261.43	69790	53060	44930	26340	5H80
74	326.96	86640	65910	55850	32824	5H86
92	390.66	104680	79610	67460	3970	5H120
110	489.74	130100	98990	83880	49290	5H126

## APPLICATION HIGH AND MEDIUM TEMPERATURE R134A

Capacity kW	Displacement m <sup>3</sup> /h	Cooling capacity Watts - Evaporating temp.				Model reference
		0°C	-5°C	-7°C	-15°C	
5.5	20.03	11800	9270	8560	7130	5F20
7.4	42.18	17600	13910	12890	10790	5F30
11	56.33	23700	18610	17180	14320	5F40
14.7	84.36	35480	27830	25690	21410	5F60
23	130.79	55930	43760	40340	33550	5H40
29	163.48	69300	54190	49940	41510	5H46
37	195.90	83890	65640	60520	50380	5H60
44	244.87	104260	81690	75370	62800	5H66
44	261.43	111780	87470	80650	67150	5H80
55	326.96	138760	108620	100190	83440	5H86
74	390.66	167970	131470	121240	100940	5H120
92	489.74	208530	163270	150590	125400	5H126

## APPLICATION LOW TEMPERATURE R22

Capacity kW	Displacement m <sup>3</sup> /h	Cooling capacity Watts - Evaporating temp.				Model reference
		0°C	-5°C	-10°C	-15°C	
7.4	20.03	19440	15580	12280	9480	5F20
11	42.18	29500	23430	18470	14280	5F30
15	56.33	38880	31240	24730	19220	5F40
23	84.36	58710	47130	37220	28830	5F60
37	130.79	92760	75270	59920	46650	5H40
44	163.48	114790	93040	74050	57720	5H46
55	195.90	139000	112880	89960	70120	5H60
74	244.87	172670	140230	111770	87120	5H66
74	261.43	185230	150730	119790	93340	5H80
92	326.96	229960	186690	148750	115950	5H86
110	390.66	278270	225900	179930	140140	5H120
132	489.74	345390	280450	223460	174140	5H126

### PERFORMANCE (contd)

#### COMPRESSOR RATINGS NOTES

- Compressor capacities are based on 1750 rpm and 15 F subcooling.

#### 5F,H Rating Limits

SAT. SUCT TEMP (F)		SAT. DISCH TEMP (F)	
MIN	MAX	MIN	MAX
-40	50	80	145*
-60	50	80	120

□ R-12, R-22      ■ R-502

\*135 F for R-22.

Refer to 5F,H compressor application data (Expanded Ratings) for ratings not shown in Compressor Ratings Tables.

#### Multiplying Factors for Other rpm

rpm	1450	1160
Capacity	.835	.674
bhp	.798	.602

- Liquid subcooling, greater than (less than) the 15 F incorporated in the ratings increases (decreases) system capacity by 1/2 of 1% for each degree of subcooling. When correcting for subcooling, brake horsepower does not change. Adjusted total heat rejection (tons) equals adjusted capacity + (.212 × bhp).
- Refrigerant temperatures shown are saturation temperatures corresponding to pressures indicated at compressor. Actual gas temperatures are higher because of superheat.
- Capacities are based on actual suction gas temperatures to the compressor of 65 F for R-12; 75 F for R-502. (This assumes superheat is obtained from liquid-suction interchanger or in evaporator.) Capacity corrections for other than rated suction gas temperatures may be obtained from Rating Basis and Capacity Multipliers table. R-22 suction gas superheat (15 F) normally occurs because of expansion valve operation and line losses. Therefore, R-22 ratings can be used without adjustment.
- All compressor power (bhp) ratings are for direct drive. For belt drive applications, belt losses must be included. Normally these belt losses are assumed to add 2 to 3% to the bhp values shown.

#### CAPACITY CONTROL REDUCTION STEPS

COMPR MODEL	CONTR CYL	CAP. STEPS (% Full Load Cap.)										
		100	87½	83½	75	66½	62½	50	37½	33½	25	
		% Full Load bhp										
		100	90	86	80	74	71	60	50	45	38	
Number of Active Cylinders												
5F20	1	2	—	—	—	—	—	1	—	—	—	—
5F30	1	3	—	—	—	2	—	—	—	1	—	—
5F40	3	4	—	—	3	—	—	2	—	—	1	—
5F60	4	6	—	5	—	4	—	3	—	2	—	—
5H40	3	4	—	—	3	—	—	2	—	—	1	—
5H46	3	4	—	—	3	—	—	2	—	—	1	—
5H60	4	6	—	5	—	4	—	3	—	2	—	—
5H66	4	6	—	5	—	4	—	3	—	2	—	—
5H80	6	8	7	—	—	—	5	—	3	—	2	—
5H86	6	8	7	—	—	—	5	—	3	—	2	—
5H120	8	12	—	10	—	8	—	6	—	4	—	—
5H126	8	12	—	10	—	8	—	6	—	4	—	—



# CARRIER

## 5F & 5H Compressors

Ordering Reference	Capacity (L)	Suction sold connection size (inch)	Discharge sold connection size (inch)	Type	Cylinder	Power R134A (CV)	Power R22 (CV)
-5-F--20-C-654D-S	2,37	1-1/8 ODF	7/8 ODF	NEWMAN	2	5,7	10
-5-F--20-S-674--S	2,37	1-1/8 ODF	7/8 ODF	NEWMAN	2	5,7	10
-5-F--20-S-684--S	2,37	1-1/8 ODF	7/8 ODF	NEWMAN	2	5,7	10
-5-F--30-A-219--S	2,6	1-5/8 ODF	1-3/8 ODF	REMAN	3	8,5	15
-5-F--30-C-664D-S	2,6	1-5/8 ODF	1-3/8 ODF	NEWMAN	3	8,5	15
-5-F--30-S-644--S	2,6	1-5/8 ODF	1-3/8 ODF	NEWMAN	3	8,5	15
-5-F--30-S-664--S	2,6	1-5/8 ODF	1-3/8 ODF	NEWMAN	3	8,5	15
-5-F--40---909--S	5,67	1-5/8 ODF	1-3/8 ODF	NEWMAN	4	11,4	20
-5-F--40-A-219--S	5,67	1-5/8 ODF	1-3/8 ODF	REMAN	4	11,4	20
-5-F--40-S-219--S	5,67	1-5/8 ODF	1-3/8 ODF	NEWMAN	4	11,4	20
-5-F--60---909--S	6,15	2-1/8 ODF	1-5/8 ODF	NEWMAN	6	17,1	25
-5-F--60-A-219--S	6,15	2-1/8 ODF	1-5/8 ODF	REMAN	6	17,1	25
-5-F--60-C-149--S	6,15	2-1/8 ODF	1-5/8 ODF	NEWMAN	6	17,1	25
-5-F--60-S-219--S	6,15	2-1/8 ODF	1-5/8 ODF	NEWMAN	6	17,1	25
-5-H-120-A-204--S	28,85	4-1/8 ODF	4-1/8 ODF	REMAN	12	81,4	125
-5-H-126---404--S	28,85	4-1/8 ODF	4-1/8 ODF	NEWMAN	12	100	150
-5-H-126-A-219--S	28,85	4-1/8 ODF	4-1/8 ODF	REMAN	12	100	150
-5-H--40---909--S	8,51	2-5/8 ODF	2-1/8 ODF	NEWMAN	4	25	40
-5-H--40-A-219--S	8,51	2-5/8 ODF	2-1/8 ODF	REMAN	4	25	40
-5-H--40-S-219--S	8,51	2-5/8 ODF	2-1/8 ODF	NEWMAN	4	25	40
-5-H--46---909--C	8,51	2-5/8 ODF	2-1/8 ODF	NEWMAN	4	40	60
-5-H--46-A-219--S	8,51	2-5/8 ODF	2-1/8 ODF	REMAN	4	40	60
-5-H--46-S-219--S	8,51	2-5/8 ODF	2-1/8 ODF	NEWMAN	4	40	60
-5-H--60-A-219--S	9,93	3-1/8 ODF	3-1/8 ODF	REMAN	6	40	60
-5-H--60-C-109--S	9,93	3-1/8 ODF	3-1/8 ODF	NEWMAN	6	40	60
-5-H--60-C-119--S	9,93	3-1/8 ODF	3-1/8 ODF	NEWMAN	6	40	60
-5-H--60-S-219--S	9,93	3-1/8 ODF	3-1/8 ODF	NEWMAN	6	40	60
-5-H--66---404--S	9,93	3-1/8 ODF	3-1/8 ODF	NEWMAN	6	50	75
-5-H--66-A-219--S	9,93	3-1/8 ODF	3-1/8 ODF	REMAN	6	50	75
-5-H--66-S-219--S	9,93	3-1/8 ODF	3-1/8 ODF	NEWMAN	6	50	75
-5-H--80-A-204--S	19,4	3-1/8 ODF	3-1/8 ODF	REMAN	8	50	75
-5-H--80-A-219--S	19,4	3-1/8 ODF	3-1/8 ODF	REMAN	8	50	75
-5-H--80-S-219--S	19,4	3-1/8 ODF	3-1/8 ODF	NEWMAN	8	50	75
-5-H--86---404--S	19,4	3-1/8 ODF	3-1/8 ODF	NEWMAN	8	75	100
-5-H--86-A-219--S	19,4	3-1/8 ODF	3-1/8 ODF	REMAN	8	75	100
-5-H--86-S-219--S	19,4	3-1/8 ODF	3-1/8 ODF	NEWMAN	8	75	100



## CARRIER

5F & 5H Compressors spare parts

Compressors

Ordering Reference	Description
05GA-501---414--S	PISTON
05GA-501---762--S	OIL PLUG
05GA-502---282--S	CARBON ROTOR
05HG-660---004--S	CRANKSHAFT
05HG-660---005--S	CRANKSHAFT
05HG-660---006--S	SEAL
05HG-660---020--S	OIL FILTER
05KA-404---093-OEM	OIL PUMP DRIVE
05KA-404---093--S	OIL PUMP DRIVE
-5-D--40--1372--S	CONNECTING ROD
-5-F--20--1002--S	BEARING (MULT 4)
-5-F--20--1011--S	GASKET (MULT 12)
-5-F--20--1012--S	BEARING
-5-F--20--1022--S	BEARING
-5-F--20--1031--S	PISTON (MULT 6)
-5-F--20--1032--S	GASKET
-5-F--20---103--C	CONNECTING ROD
-5-F--20--1052--S	COVER
-5-F--20--1083--S	GASKET (MULT 50)
-5-F--20--1093--S	GASKET (MULT 12)
-5-F--20--1113--S	GASKET
-5-F--20---112--S	GUIDE
-5-F--20--1132--S	DISC (MULT 2)
-5-F--20--1133--S	BOTTOM PLATE
-5-F--20--1142--S	DISC
-5-F--20--1191--S	INNER SEAT
-5-F--20--1301--S	WASHER (MULT 12)
-5-F--20--1311--S	ADAPTER
-5-F--20--1322--S	GUIDE
-5-F--20---132--S	STRAINER
-5-F--20--1451--S	GASKET (MULT 50)
-5-F--20--1501--S	CLIP
-5-F--20---152--C	SIGHT GLASS
-5-F--20---153--S	ELEMENT
-5-F--20--1631--S	SIGHT GLASS GASKET (MULT 12)
-5-F--20--1701--S	GASKET (MULT 12)
-5-F--20--1703--S	GASKET
-5-F--20--171112S	GASKET (MULT 12)
-5-F--20---172--C	COLLECTOR
-5-F--20--1741--S	WASHER (MULT 6)
-5-F--20--1752--S	SLEEVE
-5-F--20--1761--S	WASHER (MULT 6)
-5-F--20--1782--S	PISTON
-5-F--20--1791--S	SPRING (MULT 12)

For other codes, please consult us





## CARRIER

5F & 5H Compressors spare parts

Ordering Reference	Description
-5-F--20--1801--S	SPRING (MULT 12)
-5-F--20--1802--S	SPRING (MULT 6)
-5-F--20--1813--S	GASKET
-5-F--20--1822--S	SPRING (MULT 6)
-5-F--20---212--C	PRESSURE SWITCH
-5-F--20--2263--S	HEAD
-5-F--20--2571--S	PAD
-5-F--20--2653--S	GRILLE
-5-F--20--2751--S	PIN (MULT 6)
-5-F--20--2843--S	WASHER (MULT 12)
-5-F--20--3422--S	HALF BEARING (MULT 4)
-5-F--20--3432--S	BEARING (MULT 4)
-5-F--20--3442--S	BEARING
-5-F--20--3452--S	BEARING
-5-F--20--3462--S	BEARING
-5-F--20--3472--S	BEARING
-5-F--20---394--C	PULLEY
-5-F--20---481--S	RING
-5-F--20---482--S	PISTON
-5-F--20--4942--S	COVER
-5-F--20--5232--S	KEY
-5-F--20--5352--S	FORK
-5-F--20--660001S	GASKET
-5-F--20--660002S	SUCTION VALVE
-5-F--20---676--S	SEAL
-5-F--20---677--S	HEAD
-5-F--20---752--S	UNLOADER KIT
-5-F--20---781--S	LIQUID SIGHT GLASS
-5-F--20---847--S	COUPLING
-5-F--20---861--S	PULLEY PACKAGE
-5-F--20---891--S	PULLEY PACKAGE
-5-F--20---932--S	BEARING PULLER
-5-F--20-A-272--C	PUMP
-5-F--20-A-563--S	POWER CONTROL KIT
-5-F--20-A-752--C	UNLOADER KIT
-5-F--20-B-103--C	EXCHANGER
-5-F--30--1003--S	SLEEVE
-5-F--30--1012--S	BEARING
-5-F--30---132--S	STRAINER
-5-F--30--136101S	GASKET (MULT 12)
-5-F--30--1831--S	GASKET
-5-F--30--1844--S	CRANKSHAFT
-5-F--30---333--S	UNLOADER OIL TUBE
-5-F--30--3442--S	BEARING

For other codes, please consult us

[www.carrier-ercd.com](http://www.carrier-ercd.com)



## CARRIER

5F & 5H Compressors spare parts

Ordering Reference	Description
-5-F--30--3452--S	BEARING
-5-F--30---394--C	FLYWHEEL
-5-F--30---677--S	BEARING
-5-F--30---847--S	COUPLING
-5-F--30---921--S	PULLEY PACKAGE
-5-F--36--1032--S	GASKET
-5-F--40--1012--S	BEARING
-5-F--40--1022--S	BEARING
-5-F--40---102--S	COVER
-5-F--40--1042--C	GASKET
-5-F--40--1052--S	COVER
-5-F--40--1083--S	GASKET (MULT 12)
-5-F--40--1123--S	TUBE
-5-F--40---114--S	CRANKSHAFT
-5-F--40--1153--S	TUBE
-5-F--40--1203--S	HEAD
-5-F--40---120--S	VALVE PLATE
-5-F--40--1211--S	GASKET (MULT 12)
-5-F--40--1213--S	HEAD
-5-F--40--1233--S	TUBE
-5-F--40---132--S	STRAINER
-5-F--40---172--C	COLLECTOR
-5-F--40--1751--S	WASHER (MULT 6)
-5-F--40--1761--S	BAG OF 6 WASHERS
-5-F--40---237--S	GRILLE
-5-F--40---276--S	SEAL
-5-F--40---2783--S	SPRING (MULT 6)
-5-F--40---307--S	SEAL
-5-F--40--3442--S	BEARING
-5-F--40--3452--S	BEARING
-5-F--40--3462--S	BEARING
-5-F--40--3472--S	BEARING
-5-F--40--3742--S	CASING
-5-F--40---394--S	PULLEY
-5-F--40---401--S	MOTOR MOUNTING PACKAGE
-5-F--40---408F--S	FRAME
-5-F--40--4512--S	GASKET
-5-F--40---4F1--A	ELECTRIC UNLOADER KIT
-5-F--40---603--C	COUPLING
-5-F--40---623--C	COUPLING
-5-F--40---677--S	CYLINDER HEAD
-5-F--40---841--S	BELT
-5-F--40---881--S	PULLEY
-5-F--40-A-164--S	COVER

For other codes, please consult us





## CARRIER

5F & 5H Compressors spare parts

Ordering Reference	Description
-5-F--40-A-352--S	SUCTION FILTER
-5-F--41--1434--S	COVER
-5-F--41--1703--S	GASKET
-5-F--60--1004--S	HEAD
-5-F--60--1123--S	TUBE
-5-F--60--114--S	CRANKSHAFT
-5-F--60--1153--S	TUBE
-5-F--60--1163--S	TUBE
-5-F--60--1173--S	TUBE
-5-F--60--1233--S	TUBE
-5-F--60--132--S	SUCTION STRAINER
-5-F--60--1681--S	GASKET
-5-F--60--172--S	COLLECTOR
-5-F--60--1831--S	GASKET (MULT 12)
-5-F--60--3792--S	BAG FELT FILTER
-5-F--60--394--C	PULLEY
-5-F--60--401--S	FASTENER SET PACKAGE
-5-F--60--4FI-A	UNLOADER KIT
-5-F--60--613--S	COUPLING
-5-F--60--623--S	COUPLING
-5-F--60--660001S	GASKET
-5-F--61--502--S	GASKET
-5-H-120--1072--C	WASHER (MULT 6)
-5-H-120--1242--C	BEARING
-5-H-120--1242S3S	BEARING
-5-H-120--1279--S	MANIFOLD
-5-H-120--1334--S	OIL FILTER HOUSING
-5-H-120--1354--S	IMPELLER
-5-H-120--150--S	PUMP
-5-H-120--1593--S	SPRING (MULT 6)
-5-H-120--1643--C	SPRING (MULT 6)
-5-H-120--1683--S	SPRING (MULT 6)
-5-H-120--204--S	BEARING
-5-H-120--2113--S	LINE
-5-H-120--2133--S	TUBE
-5-H-120--2173--S	TUBE
-5-H-120--2181--S	CAP
-5-H-120--2191--S	AXLE
-5-H-120--252--S	GRILLE
-5-H-120--3301--S	STRAINER
-5-H-120--3341--S	GASKET
-5-H-120--3361--S	GASKET
-5-H-120--3381--S	VALVE CAP
-5-H-120--3401--S	SEAT

For other codes, please consult us

[www.carrier-ercd.com](http://www.carrier-ercd.com)



## CARRIER

5F & 5H Compressors spare parts

Ordering Reference	Description
-5-H-120--3411--S	DISC
-5-H-120--3441--S	GROMMET
-5-H-120---351--S	OIL FILTER
-5-H-120--3672--S	BEARING
-5-H-120--3682--S	BEARING
-5-H-120--3821--S	CAP
-5-H-120--4452--S	SUCTION MANIFOLD COVER
-5-H-120--4492--S	GASKET
-5-H-120--4502--S	FERRULE
-5-H-120--4512--S	FERRULE
-5-H-120--4522--S	FERRULE
-5-H-120--4552--S	FILTER
-5-H-120--4602--S	TUBE
-5-H-120--4612--S	TUBE
-5-H-120--4642--S	GASKET (MULT 10)
-5-H-120---4FI-1AS	ELECTRIC UNLOADER PACKAGE
-5-H-120---4FI-AS	ELECTRICAL UNLOADER KIT
-5-H-120---502--S	GASKET
-5-H-120---507--S	CYLINDER HEAD WATER COULING
-5-H-120---524--S	TUBE
-5-H-120---527--S	MOUNTING KIT
-5-H-120---562--S	CRANKSHAFT
-5-H-120---623--C	COUPLING
-5-H-120---732AS	SEAL REPLACEMENT PACKAGE
-5-H-120---732--C	SEAL
-5-H-120---782--S	OIL REGULATOR
-5-H-120---794--S	STRAINER
-5-H-120---813--S	TUBE
-5-H-120---821--S	PULLEY
-5-H-120---833--S	TUBE
-5-H-120---837--S	OIL PUMP KIT
-5-H-120---861--S	BELT
-5-H-120---972--S	TUBE
-5-H-120-A-773--S	PUMP
-5-H-120-B-283--S	OIL COOLER
-5-H-120-B-323--S	COVER
-5-H-121--1703--S	GASKET
-5-H-126---113--S	TUBE
-5-H-126---134--S	TUBE
-5-H-126---562--S	CRANKSHAFT
-5-H-126---623--S	COUPLING
-5-H--40--1001--S	LIQUID SIGHT GLASS
-5-H--40--1002--S	DEMI-COUSSINET (MULT 4)
-5-H--40--1002S3S	BEARING (MULT 4)

For other codes, please consult us



## CARRIER

5F & 5H Compressors spare parts

Ordering Reference	Description
-5-H--40--1003--S	SLEEVE
-5-H--40--1011--S	GASKET
-5-H--40--1012--S	BEARING
-5-H--40--1012S3S	BEARING
-5-H--40--1021--S	GLAND
-5-H--40--1022--S	BEARING
-5-H--40--1022S3S	BEARING
-5-H--40--102--S	COVER
-5-H--40--1031--S	BEARING
-5-H--40--1032--S	GASKET
-5-H--40--103--S	CONNECTING ROD
-5-H--40--1042--S	GASKET (MULT 12)
-5-H--40--1051--S	AXLE (MULT 6)
-5-H--40--1052--S	COVER
-5-H--40--1062--S	WASHER (MULT 6)
-5-H--40--1071--S	RING (MULT 4)
-5-H--40--1072--S	WASHER (MULT 6)
-5-H--40--1082--S	WASHER (MULT 12)
-5-H--40--1083--S	GASKET (MULT 30)
-5-H--40--1091--S	RING
-5-H--40--1093--S	GASKET
-5-H--40--1103--S	VALVE PLATE
-5-H--40--1113--S	GASKET (MULT 12)
-5-H--40--1121--S	NUT
-5-H--40--1132--C	DISCHARGE CHECK VALVE.
-5-H--40--1141--C	CAP
-5-H--40--1142--C	SUCTION CHECK VALVE
-5-H--40--1163--S	TUBE
-5-H--40--1171--S	GASKET (MULT 12)
-5-H--40--1181--S	GASKET
-5-H--40--1191--S	GASKET
-5-H--40--1201--S	LOCK WASHER
-5-H--40--1304--S	COVER
-5-H--40--1342--S	TUBE
-5-H--40--1361--S	GASKET (MULT 12)
-5-H--40--1371--S	GASKET (MULT 12)
-5-H--40--1401--S	WASHER (MULT 6)
-5-H--40--1411--S	GASKET (MULT 12)
-5-H--40--1423--S	GASKET (MULT 10)
-5-H--40--1451--S	GASKET (MULT 12)
-5-H--40--1531--S	FERRULE
-5-H--40--1541--S	FERRULE
-5-H--40--1553--S	GUIDE
-5-H--40--1621--S	GASKET (MULT 12)

For other codes, please consult us

[www.carrier-ercd.com](http://www.carrier-ercd.com)



## CARRIER

5F & 5H Compressors spare parts

Ordering Reference	Description
-5-H-40-163-S	ELEMENT
-5-H-40-1701-S	GASKET (MULT 12)
-5-H-40-1711-S	GASKET (MULT 12)
-5-H-40-1731-S	ROD
-5-H-40-1752-S	SLEEVE
-5-H-40-1782-S	PISTON
-5-H-40-1791-C	SPRING (MULT 12)
-5-H-40-1802-S	SPRING (MULT 6)
-5-H-40-1811-S	WASHER (MULT 6)
-5-H-40-1814-S	FORK
-5-H-40-1822-S	SPRING (MULT 6)
-5-H-40-1943-S	TUBE
-5-H-40-1953-S	TUBE
-5-H-40-1971-S	GRILLE
-5-H-40-1981-S	DISC
-5-H-40-2001-S	GASKET (MULT 12)
-5-H-40-2221-S	RING
-5-H-40-2231-S	AXLE (MULT 6)
-5-H-40-2241-S	SPRING (MULT 12)
-5-H-40-237-S	INTERNAL FILTER
-5-H-40-242-S	PLATE
-5-H-40-2433-S	COVER GASKET
-5-H-40-276A-S	SEAL REPLACEMENT PACKAGE
-5-H-40-276-S	SEAL
-5-H-40-2812-S	SPRING (MULT 6)
-5-H-40-323-S	STRAINER
-5-H-40-3273-S	ADAPTER
-5-H-40-3363-S	WASHER (MULT 6)
-5-H-40-3413-S	SHAFT SEAL COVER PLATE
-5-H-40-3612-S	BEARING (MULT 4)
-5-H-40-3622-S	HALF BEARING 020" (MULT 4)
-5-H-40-3632-S	BEARING
-5-H-40-3642-S	BEARING
-5-H-40-3652-S	BEARING
-5-H-40-3662-S	BEARING
-5-H-40-3692-C	GASKET
-5-H-40-394-C	PULLEY
-5-H-40-3982-S	VALVE CAP
-5-H-40-477-S	SEAL ASSEMBLY
-5-H-40-481-S	COMPRESSION & OIL RING KIT
-5-H-40-482-S	PISTON
-5-H-40-4FI-1AS	ELECTRIC UNLOADER PACKAGE
-5-H-40-502-S	GASKET
-5-H-40-507-C	CYLINDER HEAD WATER COULING

For other codes, please consult us



## CARRIER

5F & 5H Compressors spare parts

Ordering Reference	Description
-5-H--40--562--S	CRANKSHAFT
-5-H--40--588-ES	FRAME
-5-H--40--588-GS	FRAME
-5-H--40--588-HS	FRAME
-5-H--40--588-JS	FRAME
-5-H--40--588-KS	FRAME
-5-H--40--588-MS	FRAME
-5-H--40--598--K	COMPRESSOR BASE
-5-H--40--613--C	COUPLING
-5-H--40--653--S	ISOLATOR PACKAGE
-5-H--40--660002S	UNLOADER BYPASS PKG
-5-H--40--677--S	PUMP
-5-H--40--703--C	COVER
-5-H--40--711--S	FASTENER PACKAGE MOTOR
-5-H--40--7252--S	SLEEVE
-5-H--40--7322--S	SPRING (MULT 12)
-5-H--40--772--S	TUBE
-5-H--40--871--S	BELT
-5-H--40-A-274--C	OIL FILTER
-5-H--40-A-372--S	PUMP
-5-H--40-A-564--S	CYLINDER HEAD
-5-H--40-B-283--S	OIL COOLER
-5-H--40-B-303--S	CARBON WASHER
-5-H--40-B-343--S	PUMP
-5-H--41--1019--S	HEAD
-5-H--41--1703--S	GASKET
-5-H--46--1003--S	SLEEVE
-5-H--46--1071--S	RING
-5-H--46--114--S	CRANKSHAFT
-5-H--46--481--S	RING PACKAGE
-5-H--46--482--S	PISTON
-5-H--60--1004--S	HEAD
-5-H--60--1133--S	TUBE
-5-H--60--1143--S	TUBE
-5-H--60--114--S	CRANKSHAFT
-5-H--60--1153--S	TUBE
-5-H--60--1163--S	TUBE
-5-H--60--1203--S	HEAD
-5-H--60--1213--S	HEAD
-5-H--60--132--S	STRAINER
-5-H--60--1342--S	TUBE
-5-H--60--1632--S	GASKET (MULT 12)
-5-H--60--1681--S	GASKET (MULT 12)
-5-H--60--1714--S	FLANGE

For other codes, please consult us

[www.carrier-ercd.com](http://www.carrier-ercd.com)



## CARRIER

5F & 5H Compressors spare parts

Ordering Reference	Description
-5-H--60--1831--S	GASKET
-5-H--60---394--C	PULLEY
-5-H--60---4032-S	SUCTION FILTER
-5-H--60--4F1-1AS	ELECTRIC UNLOADER PACKAGE
-5-H--60---502--S	GASKET
-5-H--60---507--C	CYLINDER HEAD
-5-H--60---613--C	COUPLING
-5-H--60---623--S	COUPLING
-5-H--60--7192--S	PAD
-5-H-660---005--S	ADAPTER
-5-H-660---006--S	ADAPTER
-5-H--66---562--S	CRANKSHAFT
-5-H--80--1242--C	BEARING
-5-H--80--1242S3S	BEARING
-5-H--80--1632--S	GASKET
-5-H--80--1774--S	ADAPTER
-5-H--80--1794--S	ADAPTER
-5-H--80--1892--S	COVER
-5-H--80---204--S	BEARING
-5-H--80---323--S	STRAINER
-5-H--80--3672--S	BEARING
-5-H--80--3682--S	BEARING
-5-H--80---394--C	PULLEY
-5-H--80--4962--C	GASKET
-5-H--80---502--S	GASKET
-5-H--80---507--S	WATER COOLED CYLINDER HEAD PACKAGE
-5-H--80---562--S	CRANKSHAFT
-5-H--80---613--S	COUPLING
-5-H--80---663--S	COUPLING
-5-H--80---673--S	VIBRATION ISOLATOR PACKAGE
-5-H--80--821--S	PULLEY
-5-H--80--853--S	TUBE
-5-H--81--1551--S	FERRULE
-5-H--86---562--S	CRANKSHAFT